

भारतीय मानक
Indian Standard

IS 16144 : 2014
(Reaffirmed 2020)

अनाज भंडारण गोदामों के लिए
रीति संहिता

Foodgrain Storage Godowns —
Code of Practice

ICS 55.220; 67.060

© BIS 2014



भारतीय मानक ब्यूरो
BUREAU OF INDIAN STANDARDS
मानक भवन, 9 बहादुरशाह ज़फर मार्ग, नई दिल्ली-110002
MANAK BHAVAN, 9 BAHADUR SHAH ZAFAR MARG
NEW DELHI-110002
www.bis.org.in www.standardsbis.in

March 2014

Price Group 8

Foodgrains, Starches and Ready-to-Eat Foods Sectional Committee, FAD 16

FOREWORD

This Indian Standard was adopted by the Bureau of Indian Standards, after the draft finalized by the Foodgrains, Starches and Ready-to-Eat Foods Sectional Committee had been approved by the Food and Agriculture Division Council.

In the post-green revolution era, there has been a significant growth in the production and productivity in the Indian agriculture. The country has become self-sufficient in foodgrains and achieved a remarkable growth in the production of pulses, oil seeds and fibers to meet the requirements of the country. The facility for storage of agricultural produce needs to be strengthened in the country and the creation of storage facilities, through construction of foodgrain godowns is likely to fulfil this requirement. The pre-treatment necessary for better storage life is cleaning and drying of the grain, but storage structure design and its construction also play a vital role in reducing or increasing the losses during storage. Storage losses constitute a major share of foodgrain loss in post-production operations. Scientifically designed storage structures reduce the losses and their existence provide confidence to the farmers for raising crops with quality/costly inputs.

For the purpose of deciding whether a particular requirement of this standard is complied with, the final value, observed or calculated, expressing the result of a test or analysis, shall be rounded off in accordance with IS 2 : 1960 'Rules for rounding off numerical values (*revised*)'. The number of significant places retained in the rounded off value should be the same as that of the specified value in this standard.

Indian Standard

FOODGRAIN STORAGE GODOWNS — CODE OF PRACTICE

1 SCOPE

This Indian Standard covers the basic requirements for foodgrain storage godowns. The storage godowns covered in this standard are conventional masonry structures. This Code does not apply to storage of perishables or those commodities which require storage under controlled temperature like cold storage etc.

2 REFERENCES

The standards given below contain provisions which, through reference in this text, constitute provisions of this standard. At the time of publication, the editions indicated were valid. All standards are subject to revision, and parties to agreements based on this standard are encouraged to investigate the possibility of applying the most recent editions of these standards.

<i>IS No.</i>	<i>Title</i>
277 : 2003	Galvanized steel sheets (plain and corrugated) — Specification (<i>sixth revision</i>)
456 : 2000	Plain and reinforced concrete — Code of practice (<i>fourth revision</i>)
459 : 1992	Corrugated and semi-corrugated asbestos cement sheets — Specification (<i>third revision</i>)
800 : 2007	General construction in steel — Code of practice (<i>third revision</i>)
806 : 1968	Code of practice for use of steel tubes in general building construction (<i>first revision</i>)
875	Code of practice for design loads (other than earthquake) for buildings and structures:
(Part 1) : 1987	Dead loads — Unit weights of building material and stored materials (<i>second revision</i>)
(Part 2) : 1987	Imposed loads (<i>second revision</i>)
(Part 3) : 1987	Wind loads (<i>second revision</i>)
(Part 4) : 1987	Snow loads (<i>second revision</i>)
(Part 5) : 1987	Special loads and combinations (<i>second revision</i>)
1003 (Part 2) : 1994	Timber panelled and glazed shutters — Specification: Part 2 Windows and ventilator shutters (<i>third revision</i>)
1077 : 1992	Common burnt clay building bricks — Specification (<i>fifth revision</i>)

<i>IS No.</i>	<i>Title</i>
1161 : 1998	Steel tubes for structural purposes — Specification (<i>fourth revision</i>)
1239 (Part 1) : 2004	Steel tubes, tubulars and other wrought steel fittings — Specification: Part 1 Steel tubes (<i>sixth revision</i>)
1626	Asbestos cement building pipes and pipe fittings, gutters and gutter fittings and roofing fittings — Specification:
(Part 1) : 1994	Pipe and pipe fittings (<i>second revision</i>)
(Part 2) : 1994	Gutter and gutter fittings (<i>second revision</i>)
1893 : 1984	Criteria for earthquake resistant design of structures (<i>fourth revision</i>)
1905 : 1987	Code of practice for structural use of unreinforced masonry (<i>third revision</i>)
2190 : 2010	Selection, installation and maintenance of first-aid fire extinguishers — Code of practice (<i>fourth revision</i>)
2645 : 2003	Integral waterproofing compounds for cement mortar and concrete — Specification (<i>second revision</i>)
3007 (Part 1) : 1999	Laying of asbestos cement sheets — Code of practice: Part 1 Corrugated sheets (<i>first revision</i>)
3594 : 1991	Code of practice for fire safety of industrial buildings: General storage and warehousing including cold storage (<i>first revision</i>)
4326 : 1993	Earthquake resistant design and construction of buildings — Code of practice (<i>second revision</i>)
6151 (Part 1) : 1971	Storage management code: Part 1 Terminology
6313 (Part 2) : 2001	Code of practice for anti-termite measures in buildings: Part 2 Pre-constructional chemical treatment measures (<i>second revision</i>)

3 TERMINOLOGY

For the purpose of this standard, the definitions given in IS 6151 (Part 1) shall apply in addition to the following:

IS 16144 : 2014

3.1 Foodgrain — All cereals, pulses and millets meant for human consumption.

4 LOCATION

4.1 The godown shall be located on a raised well-drained site not liable to flooding or inundations and it shall be away from a place likely to be affected by seepage water.

4.2 In selecting the location, maximum attention should be paid to the hygienic and sanitary conditions of the area and the construction in residential areas shall be avoided, as far as possible. The following minimum distances shall be maintained:

- | | |
|--|-------|
| a) Bone crushing mills, garbage dumping grounds, slaughter houses, tanneries and hide curing centres, sewage treatment plants, or such other places, the vicinity of which is deleterious to the safe storage of non-perishable agricultural commodities | 500 m |
| b) Kilns, dairies (processing units) and poultry runs | 300 m |
| c) Factories and other sources of fire and environmental hazard such as workshops, hay stacks, timber stores, petrol pumps, CNG stations and LPG bottling plants. | 150 m |

4.3 The godown should be free from passing over of any high tension electric line and in the event of such lines passing over, then the relevant Electrical Code provisions should be taken into account while planning the storage godown. The godown should be free from gas/oil pipe lines.

4.4 There shall be no tree, the roots of which affect the foundation, near the godown. The godown shall always be kept clear of branches of trees, poles, etc, by at least 3 m by which rats and squirrels would otherwise find access into it. Necessary precautions for preventing attacks by termites shall be taken.

4.5 The godown may preferably be situated near a transport head or a main road. If the godown is located in the interior, then it must have accessibility through an approach road.

4.6 At the site of the godown, there shall be sufficient parking and maneuvering space for vehicles. If the godown is situated at a ferry head, railway station, airport, etc, sufficient berthing, loading and unloading facilities shall be made available.

5 ANCILLARY STRUCTURES AND OTHER AMENITIES

5.1 It is desirable to have ancillary structures attached to godowns having capacity of 5 000 tonnes and above.

The other details of the ancillary structures for small and big godowns are given in Annex A.

6 CAPACITIES AND DIMENSIONS

6.1 The recommended capacities and dimensions of storage godown are given in Table 1. The capacities have been estimated on the basis of 22 bags high stacks of 50 kg capacity each. The stacking arrangement shall be as shown in Fig. 1.

6.2 The foodgrain storage godown shall be of single span according to the availability of land. In larger storage godowns, suitable compartments may be provided according to the local requirement. General plans for typical bagged foodgrain godowns for capacity 1 000 tonnes and its multiples including the recommended arrangement for stacking of bags and partition walls are given in Fig. 1 and Fig. 2.

Table 1 Capacities and Dimensions of Bagged Storage Godowns
(Clause 6.1)

Type of Godown	Capacity (Tonnage)	Internal Dimensions	
		Length m (3)	Breadth m (4)
(1)	(2)		
Small	100	12	7.5
	250	20	9
	500	34	12
	1 000	35.5	18
	2 500	97.19	14.48
Large	5 000	124.01 ¹⁾	21.34

NOTES

1 The size of the large capacity godown has been arrived at keeping the normal maximum size of each stack to 9.15 m x 6.10 m that may be adopted for stack fumigation.

2 The above dimensions may be suitably adopted depending upon the availability of land.

3 For storage capacity 2 500 tonnes and above, godowns may be divided in suitable compartments depending upon the availability of land.

¹⁾ For three compartment designs.

7 FOUNDATION

7.1 Suitable foundation depending upon the site conditions may be provided. The type of foundations will depend upon the property of the subsoil and the same may be provided according to relevant Indian Standard codes.

7.2 The foundation of longitudinal, gable/partition walls shall, in no case, be less than one metre deep unless hard rock is met within a shallow depth, even then a minimum depth of footing not less than 75 cm shall be provided. The foundation shall not be less than 120 cm deep under the cement concrete columns.

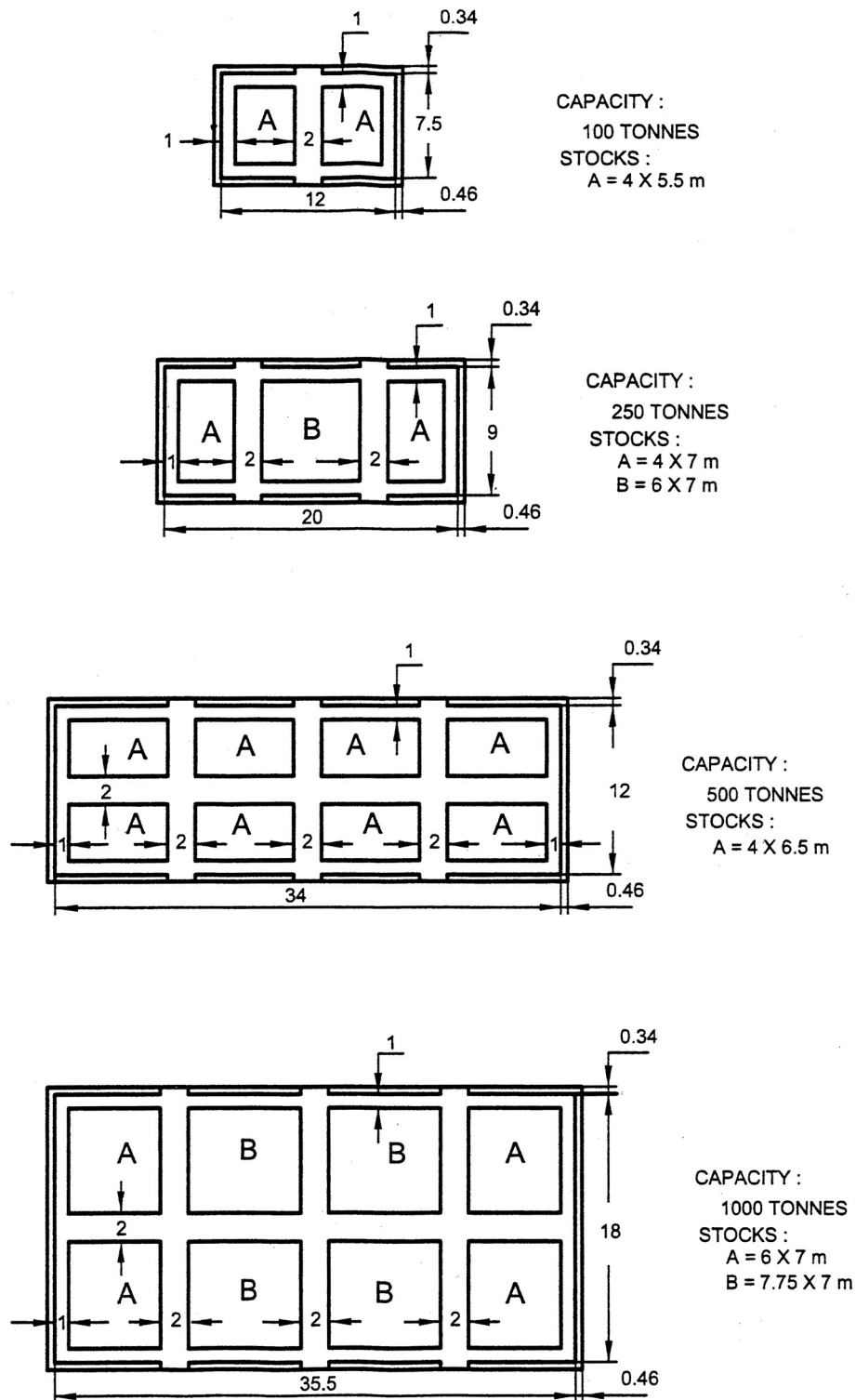

All dimensions in metres.

FIG. 1 STACKING ARRANGEMENT (Contd.)

IS 16144 : 2014

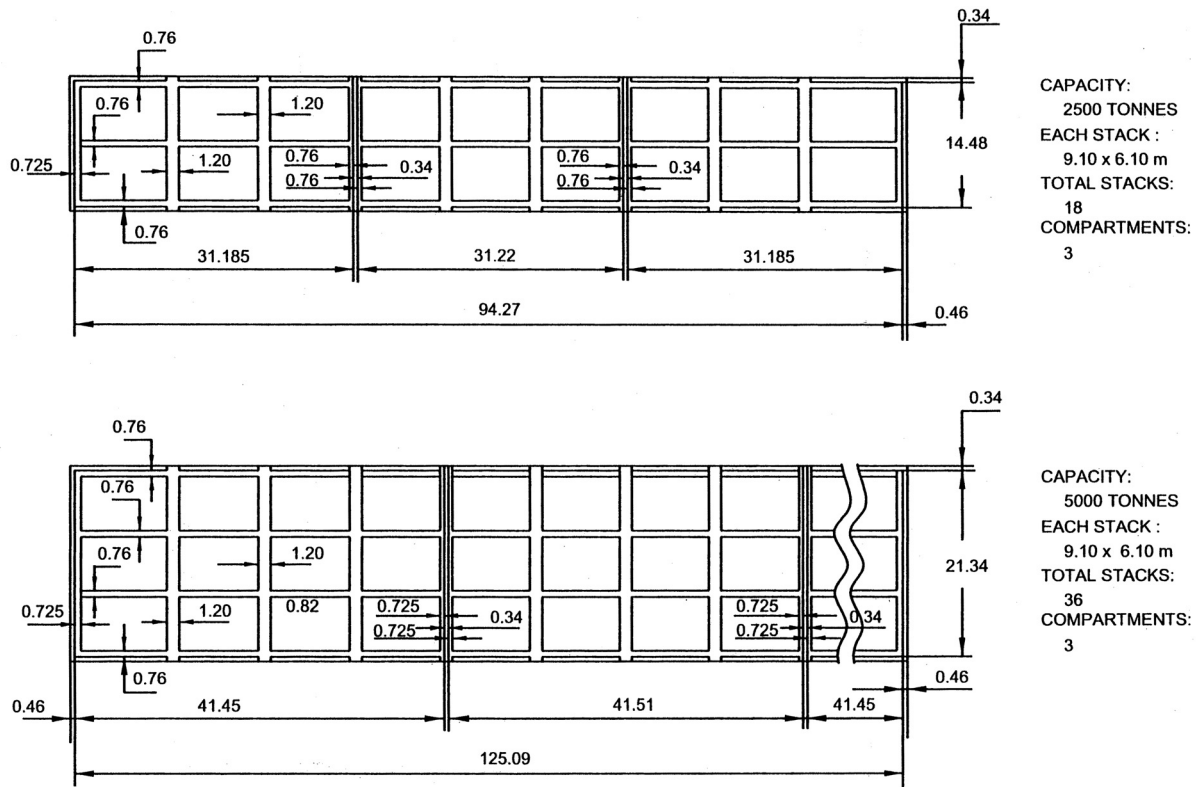

All dimensions in metres.

FIG. 1 STACKING ARRANGEMENT

7.3 Wherever rock is met within the foundation depth, it shall be properly dressed, levelled and, if necessary, cut in horizontal steps so as to receive the footings of the foundation.

7.4 The foundation, in general, shall consist of the bed of cement concrete in accordance with IS 456, not leaner than the mix of 1 : 5 : 10 (1 cement : 5 fine aggregate : 10 coarse aggregate of 40 mm nominal size) for the walls and under the footing of the columns. The reinforced cement concrete columns shall be of mix not leaner than 1 : 1.5 : 3 (1 cement : 1.5 fine aggregate : 3 fine aggregate of 20 mm nominal size) for the nominal mix concrete and M 25 for the controlled concrete as per the requirement of design. The course of the lean concrete under the footings of the walls and RCC columns shall not be less than 7.5 cm or otherwise as per the recommendation in the structural designs.

NOTE — Fine aggregate wherever mentioned in the standard means sand having the fineness modulus 2.5 and above.

7.5 The foundation shall be carried to hard soil and to a depth at which cracks in the soil do not exist and where the bearing capacity is adequate to withstand the intensity of foundation pressure. The bearing capacity of the soil shall be properly investigated.

7.6 The foundation on both the sides shall be refilled with selected earth/locally available material suitable for filling and free from salt, organic or other foreign matter or with sand except the seashore sand or moorum which shall be compacted and made flush with the ground level.

7.7 To meet the menace of termites, suitable pesticidal treatment shall be done [see IS 6313 (Part 2)].

8 PLINTH

8.1 The plinth shall generally be kept 80 cm above the finished ground level and in exceptional cases, depending upon the topography of the land, the plinth height can be extended upto 90 cm to 120 cm, for the road-fed godowns whereas for the rail-fed godowns, the plinth height shall be 106 cm above the top of the rail for corresponding broad gauge track. The minimum width of platform for the road-fed godowns shall be 183 cm and 244 cm for rail-fed godowns. To prevent rain water from getting inside the godowns through the doors, the platform shall be provided with a slope of at least 1 in 40 from the wall to its outer edge. In case of the road-fed godowns, the platform plinth level of the godown should be fixed taking the highest flood level of any nearby/adjointing water bodies/canals/

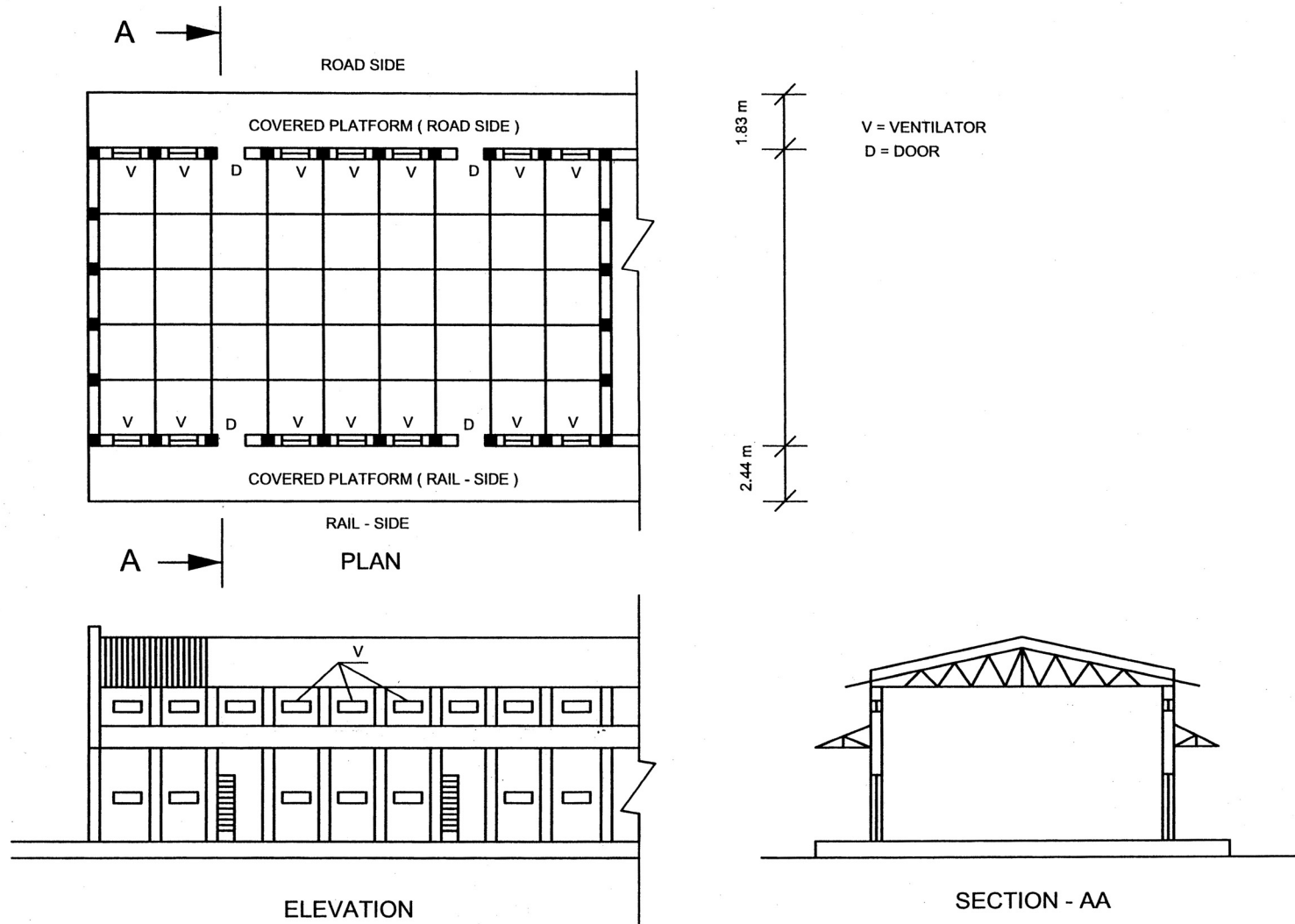
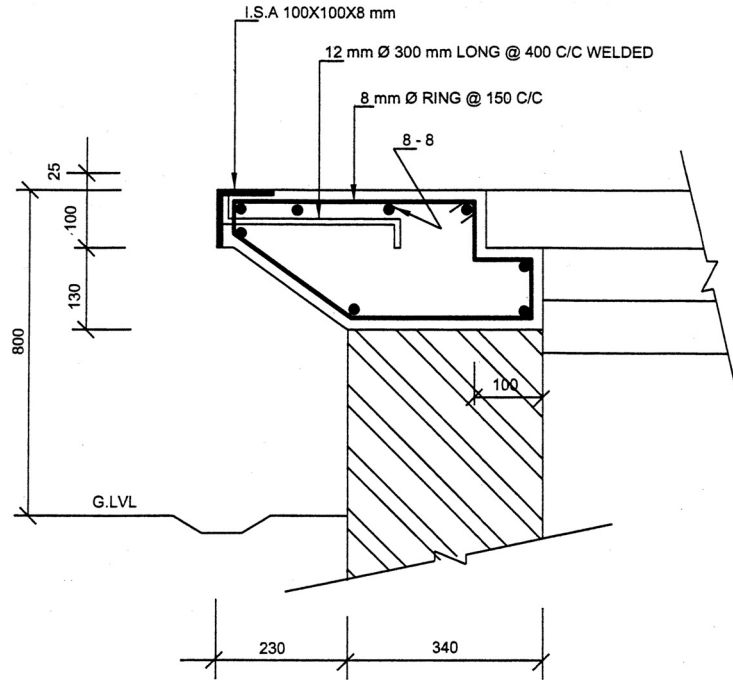

FIG. 2 TYPICAL BAGGED FOODGRAIN STORAGE GODOWN WITH RAILSIDE PLATFORM ON ONE SIDE AND ROADSIDE PLATFORM ON THE OTHER SIDE

IS 16144 : 2014

rivers/nallahs etc, into account, and it should be at least 500 mm above the highest flood level. The general

arrangement of platform plinth with nosing/coping details and other particulars is shown in Fig. 3.



R.C.C. NOSING / COPING FOR ROAD - SIDE PLATFORM

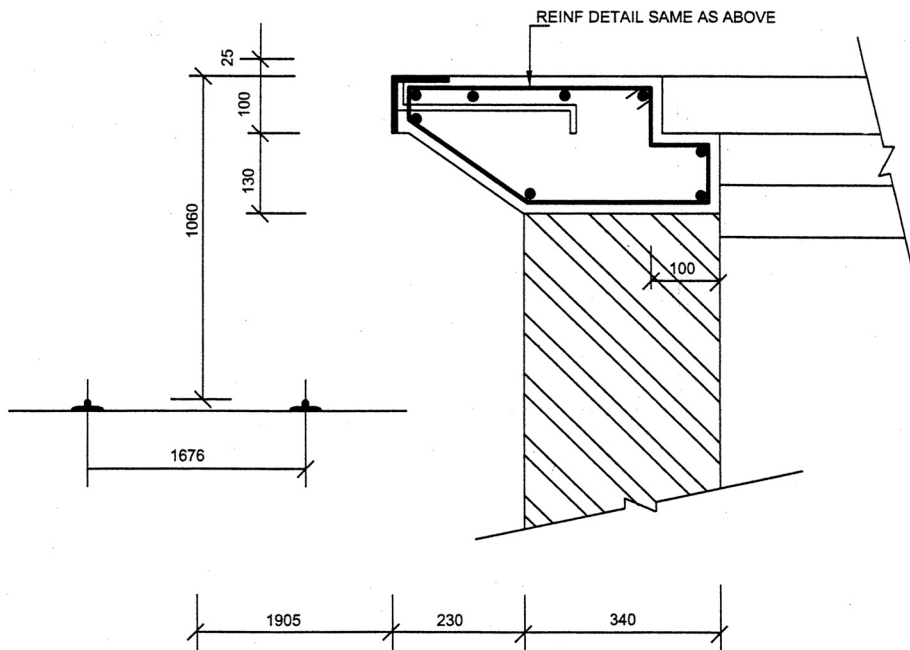

R.C.C. NOSING / COPING FOR RAIL - SIDE PLATFORM

All dimensions in millimetres.

FIG. 3 GENERAL ARRANGEMENT FOR PLATFORM PLINTH WITH NOSING/COPING

8.1.1 Wherever platforms are provided, they shall preferably be covered.

8.2 Filling of Plinth and Foundation

The plinth shall be filled with selected earth/locally available material depending upon the availability (excluding black cotton soils and other unsuitable soils), in layers not exceeding 200 mm and each layer being watered, well rammed and consolidated. When filling reaches the finished level, the surface may be flooded with water for at least 24 h, allowed to dry and then rammed and consolidated in order to avoid any settlement at a later stage. These layers shall be taken up to the formation level for the earth filling and finished level of earth so filled may be kept in slope in *verandahs*/platforms in consonance with the slope to be provided in platforms.

8.3 The plinth shall be constructed either with stone or brick masonry in cement mortar 1 : 6 (1 cement : 6 fine aggregate) including gable walls. It shall be provided with damp proof course of well graded concrete with waterproofing compound (*see* IS 2645) to a minimum thickness of 40 mm on brick masonry and a leveling course of concrete in stone masonry.

NOTE — These are the usual specifications adopted for such godowns. The actual specifications shall be based on proper designs and stresses developed depending upon the strength of raw material and mortar to be used. In seismic areas, suitable precautions may be observed in the construction of building which should be according to IS 1893 and IS 4326.

In case of non-availability of bricks and stone for masonry work, cement concrete hollow blocks may be used and their jointing etc. may be done with cement mortar 1 : 4 (1 cement : 4 fine aggregate).

8.4 Plinth Protection

The godown shall be provided with plinth protection of at least 900 mm width excluding platform portion around the godown and shall have minimum outward slope of 1 in 48 for satisfactory drainage of rain water. The plinth protection shall not be required on the side where rail side platform is provided. The plinth protection may consist of a layer of 115 mm thick brick or stone ballast, consolidated dry to the required slope, the surface shall be grouted evenly with fine sand 0.06 m³/10 m² and slightly sprinkled with water and rammed. A topping of 50 mm thick cement concrete (1 cement : 3 fine aggregate : 6 coarse aggregate) may be laid in alternate panel slabs over a well-rammed brick or stone ballast and finished smooth at top. The finished surface may have a minimum outward slope of 1 in 48. Any other mode of the plinth protection may be adopted depending upon the site condition and economy of the materials for a particular locality. If vehicular traffic is likely to come on the plinth

protection, the same should be suitably designed as a pavement in such portions.

8.4.1 It may be ensured that wherever plinth protection is laid on filled up earth, such filling shall be with selected earth/locally available material properly consolidated. Black cotton soil shall not be used in such filling.

9 FLOOR

9.1 The flooring in the storage godown should be damp proof, rigid, durable and free from any cracks or crevices.

9.1.1 The following types of flooring may be provided in the godown (Fig. 4):

- a) Selected earth/locally available material filling as per requirement, well consolidated and stabilized to avoid possibility of settlement and cracks;
- b) A layer of sand filling, 230 mm thick, thoroughly watered and well consolidated;
- c) A layer of cement concrete [(1 : 4 : 8) (1 cement : 4 coarse sand : 8 stone aggregate of 40 mm nominal size)], 100 mm thick; and
- d) A top wearing course of 50 mm thick cement concrete flooring in 1 : 2 : 4 mix (1 cement : 2 coarse sand : 4 stone aggregate of 20 mm nominal size), finished with a floating coat of neat cement shall be provided. The cement concrete flooring shall be laid in panels not exceeding 2.0 m² in area and not more than 2.0 m in any direction. Such panels shall be suitably adjusted so as to avoid transfer of any uneven load at the joints under the stacking bays and alleyways. The panels shown in Fig. 5 may be suitably adopted.

9.1.2 Alternatively the flooring and the course of the water bound macadam (WBM) underneath the cement concrete flooring (Fig. 6) should be provided as under:

- a) Selected earth/locally available material in the filling as per requirement, well compacted and stabilized for avoiding possibility of any future settlement and cracks etc. Black cotton soil and other unsuitable soils shall not be used for filling purpose;
- b) 150 mm thick WBM with stone aggregate of size 63-45 mm (Grade II) with corresponding screening and binding material to be properly consolidated as per requirement;
- c) 75 mm thick WBM to be laid with 53-22.4 mm sized stone aggregate (Grade III) with corresponding screening and binding material to be properly consolidated as per requirement; and

IS 16144 : 2014

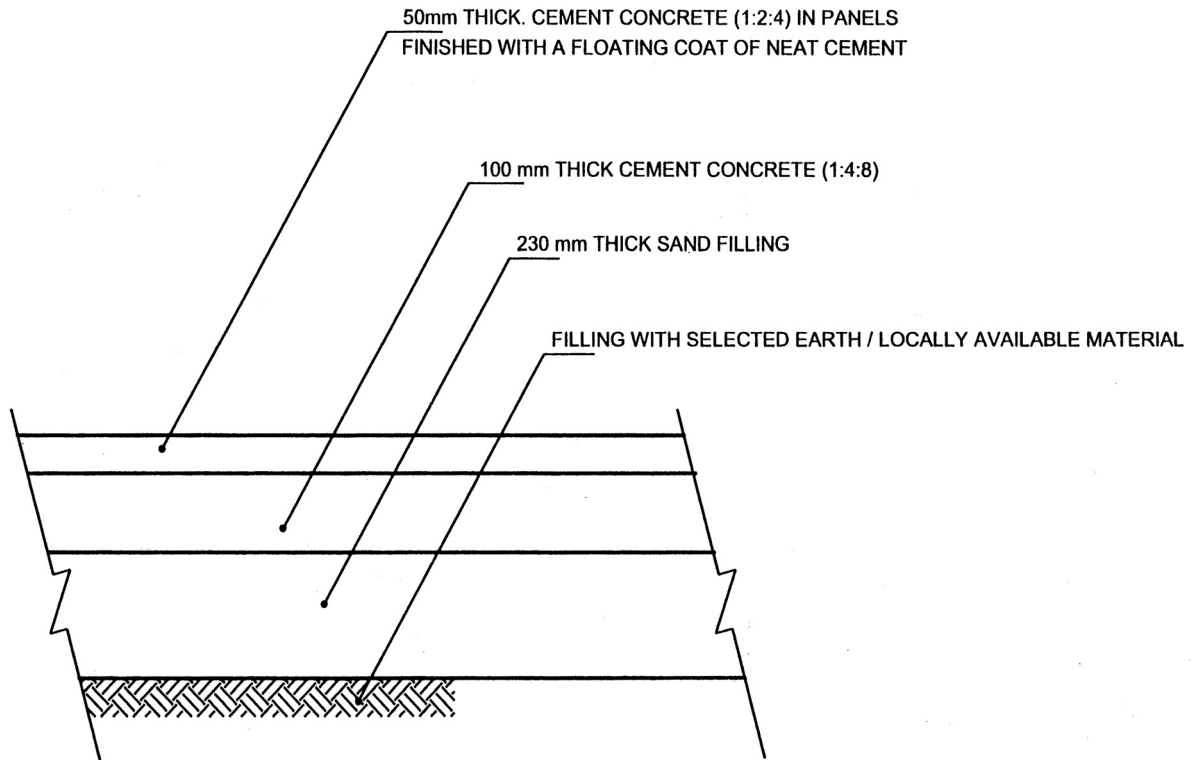

FIG. 4 DETAILS OF FLOORING (MAIN GODOWN)

- d) 50 mm thick cement concrete flooring in the cement concrete mix of 1 : 2 : 4 (1 cement : 2 fine aggregate : 4 coarse aggregate) finished with a floating coat of cement.

9.1.3 Paneling in the cement concrete flooring shall be provided with glass strip having thickness 4 mm and depth as per the thickness of the floor, as per the general arrangement of glass strips shown in Fig. 5.

10 WALLS

10.1 The design of the walls shall be in accordance with the general constructional practices (*see* IS 1905) and care shall be taken that the tensile stresses do not exceed the cracking limit. The following type of walls may be provided for the storage godown.

10.1.1 The longitudinal walls shall be of brick or stone masonry or fly ash bricks of minimum strength 50 kg/cm² in cement mortar 1 : 6 (1 cement : 6 fine aggregate) and shall be at least 5 600 mm high for road-fed as well as rail-fed godowns from the plinth level. They shall be at least 230 mm in thickness. Wherever there is non-availability of bricks/stone for masonry work, alternatively CC hollow blocks of suitable size of mix 1 : 3 : 6 (1 cement : 3 fine aggregate : 6 coarse aggregate of 6 mm nominal size) should be used. RCC columns should be provided to support the trusses connected with the beams at the top level and

one more beam of RCC in the concrete mix 1 : 1.5 : 3 (1 cement : 1.5 fine aggregate : 3 coarse aggregate of 20 mm nominal size) or the controlled concrete of minimum grade of M 25 or equivalent should be provided at the door level in the areas falling under seismic zone IV and V. The gable wall and the partition wall should be provided with the same type of masonry being provided in the longitudinal walls in the cement mortar of same ratio/mix and shall be at least 340 mm in thickness. The cement concrete work shall be in accordance with IS 456.

The walls shall be flush with the inner surface of the column and shall be plastered in cement mortar 1 : 6 (1 cement : 6 fine sand). They shall be rendered smooth both on the outer and the inner surfaces. There shall be no offsets or projections in the wall. The inside edges of the wall where they meet the floor and all corners shall be rounded off to a radius of at least 50 mm. Spacing of the RCC columns is recommended ideally as 4 650 mm from centre to centre which may also be altered as per the requirement/design/dimension of the site/plot for optimum utilization. In seismic areas, structural engineer should be consulted for giving the earthquake resistant designs of the godown and criteria for earthquake resistant designs of structures as per IS 1893 and for earthquake resistant construction as per IS 4326 shall be followed.

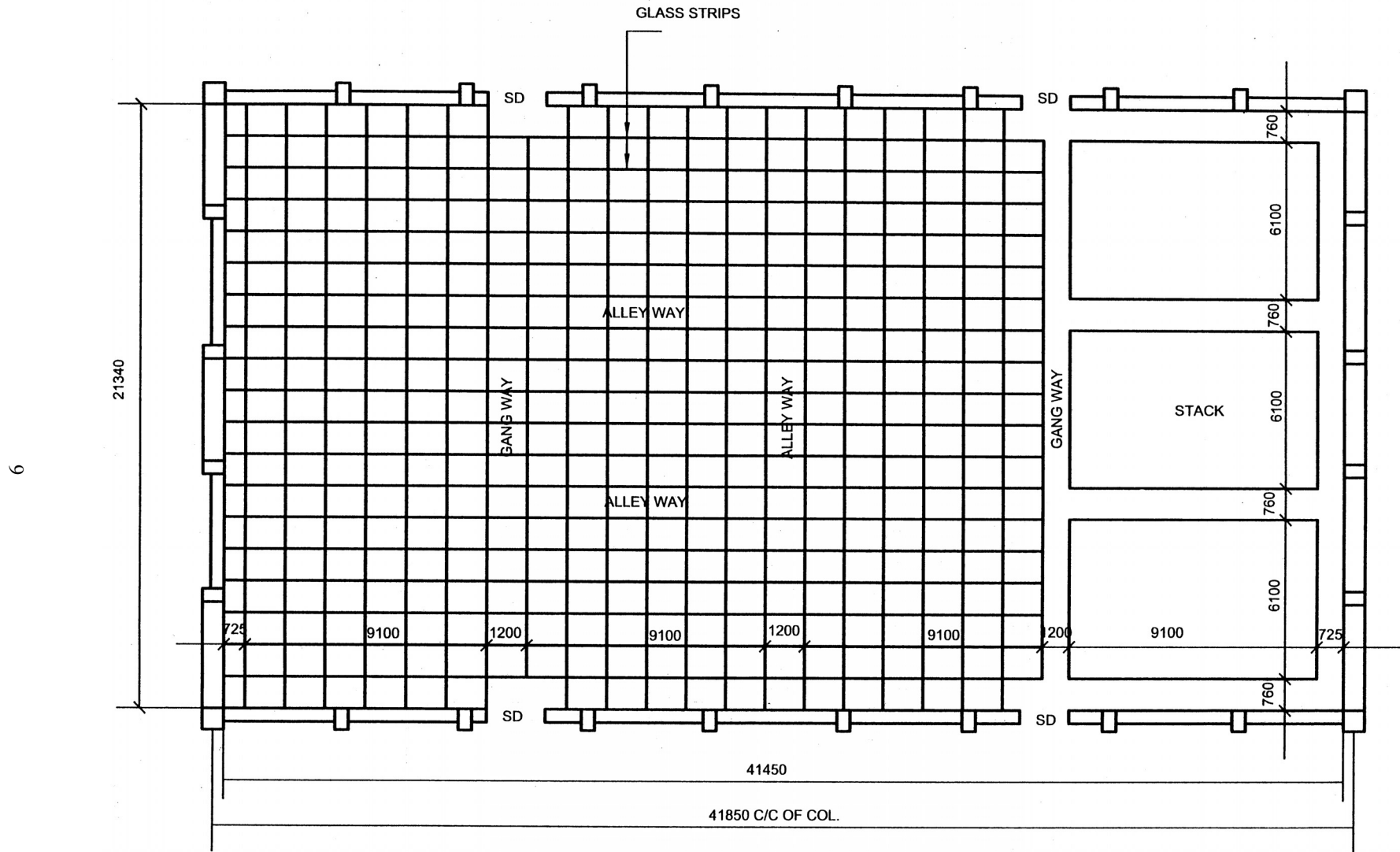

All dimensions in millimetres.

FIG. 5 TYPICAL ARRANGEMENT OF FLOOR PANELS AND STACK PLAN

IS 16144 : 2014

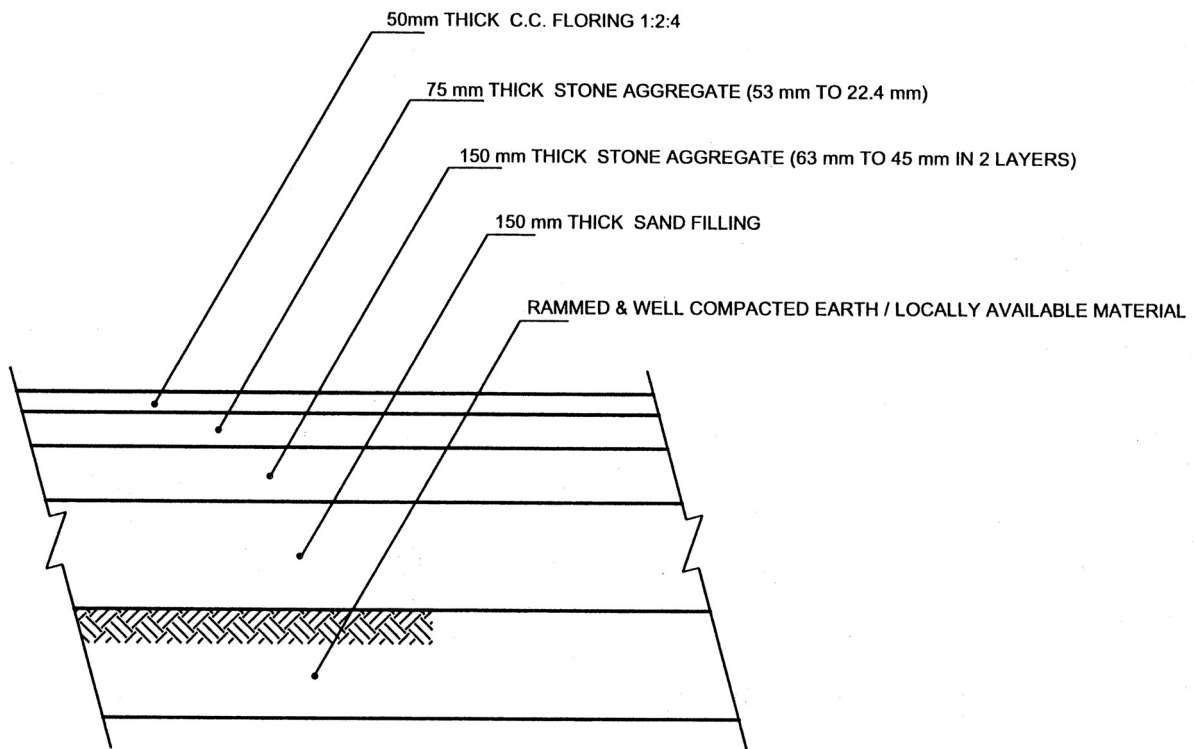

FIG. 6 DETAILS OF FLOORING

NOTE — Where modular bricks are used according to IS 1077, thickness of the walls may be kept as 300 mm (nominal) for the longitudinal and intermediate partition walls and 400 mm (nominal) for the gable walls.

11 DOORS AND VENTILATORS

11.1 Door shall be provided preferably opposite each gangway. The doors shall be of rolling shutters and fixed into suitably prepared openings. The doors shall be not less than 1 830 mm × 2 450 mm (*see* Fig. 7). Regular and periodical inspections and maintenance of the rolling shutters should be carried out to avoid defects and damages. Alternatively, the garage door (clear opening 1 830 mm × 2 450 mm) as per the details shown in Fig. 8 may also be used in view of its less maintenance, especially in the remote areas.

11.2 Ventilators

In longitudinal walls, one steel ventilator of opening not less than 1 494 mm × 594 mm shall be provided in each bay between RCC columns spaced at 4 650 mm from centre to centre. The ventilators shall be fixed 150 mm below the top of the tie beam, that is truss level of the godown. They shall be provided with glazed centre hung with fixed wire-mesh shutters (*see* Fig. 9 and Fig. 10). The frames of the ventilators shall be provided with suitable beading to avoid any chance of air and moisture leakage. Air inlets of steel ventilator

620 mm × 620 mm in each bay shall also be provided at 600 mm above the floor level of the godown (*see* Fig. 11) except those which have a rolling shutter opening or garage door. These shall be protected by expanded metal/hard drawn steel wire fabric from inside (*see* Fig. 11). When closed, the shutter shall fit tight in frame. On gable walls, suitable number of steel ventilators glazed fixed with fixed wire-mesh may be provided, if required. These ventilators shall be protected by sunshade of at least 460 mm projection. Where good local timber is available or in coastal region where steel may be subjected to salt action, timber ventilators may be provided [*see* IS 1003 (Part 2)].

12 ROOF

12.1 The roof of the godown shall be of single span structural steel or tubular trusses which shall be fixed on the RCC columns or RS joists at a height not less than 5 600 mm from the plinth level to the tie level at the column ends, both for the road-fed and rail-fed storage godowns (*see* Fig. 12).

12.2 The roof of the platforms shall be of a cantilever structural steel or tubular trusses fixed on to RCC columns at a height not less than 4 000 mm from plinth/floor level for rail-fed godowns with broad gauge railway line. The height shall be measured from the

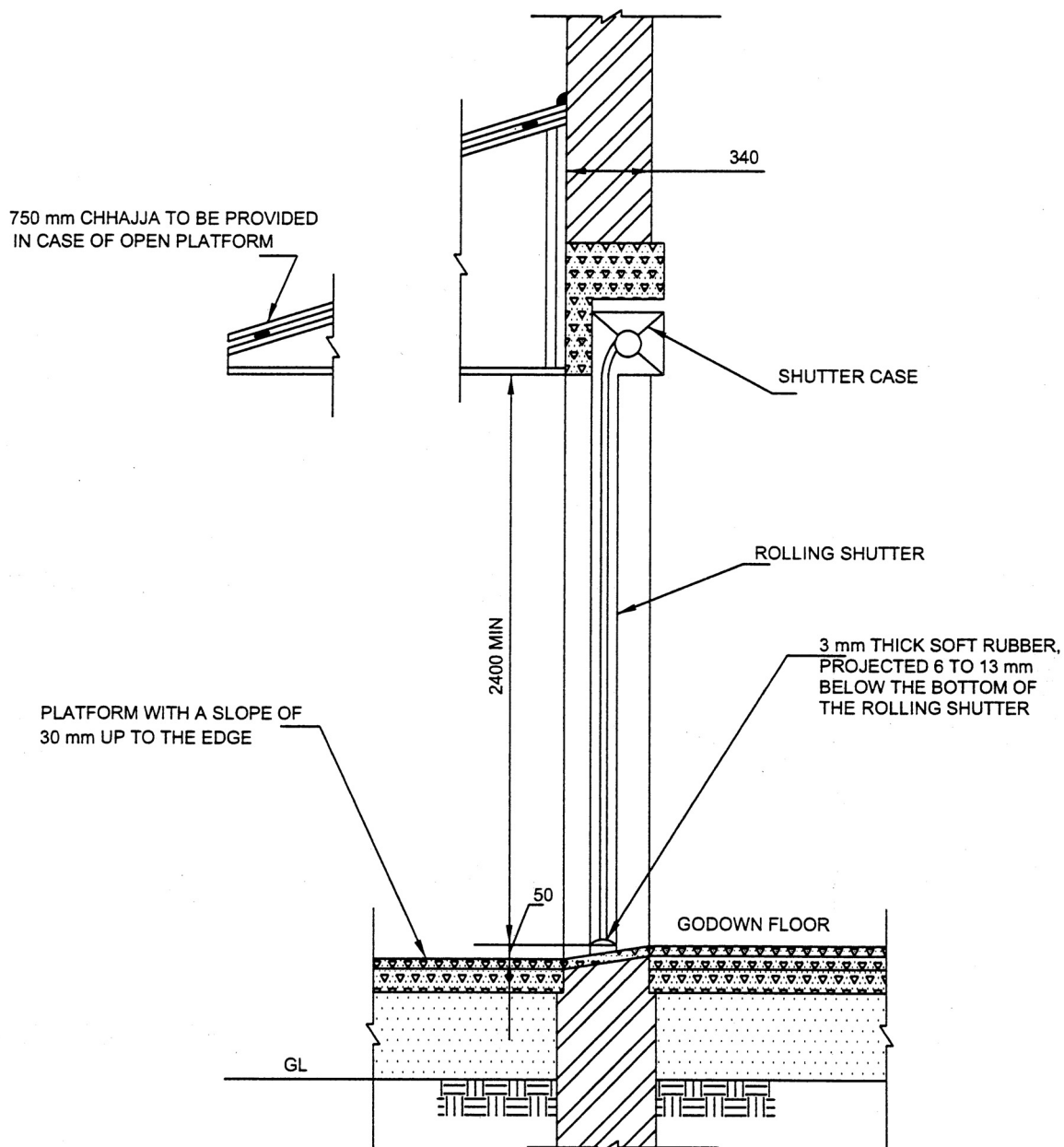

All dimensions in millimetres.

FIG. 7 DETAILS OF ROLLING SHUTTER

floor level of the godown to the bottom tie of the truss. Outer edge of the truss including valley gutters should not go beyond the line of the edge/RCC coping of the platform. The minimum width of platforms for railside and roadside shall be 2 450 mm and 1 830 mm, respectively, which shall be measured from the face of the columns.

12.3 The design of the trusses shall be in accordance with the general constructional practices and relevant Indian Standard codes for loading standards [see IS 875 (Parts 1, 2, 3, 4 and 5)] and tubular trusses [see IS 806,

IS 1161, IS 1239 (Part 1) and IS 800]. Trusses made of mild steel (MS) structural like angle and channels may also be used as per structural designs.

12.4 The trusses shall be connected by suitable sets of wind bracings and longitudinal runners etc. at the levels as per the recommendations of the structural designer of the truss.

12.5 Roofing

Materials may be corrugated asbestos sheets (see IS 459) or galvanized corrugated sheets (see IS 277),

IS 16144 : 2014

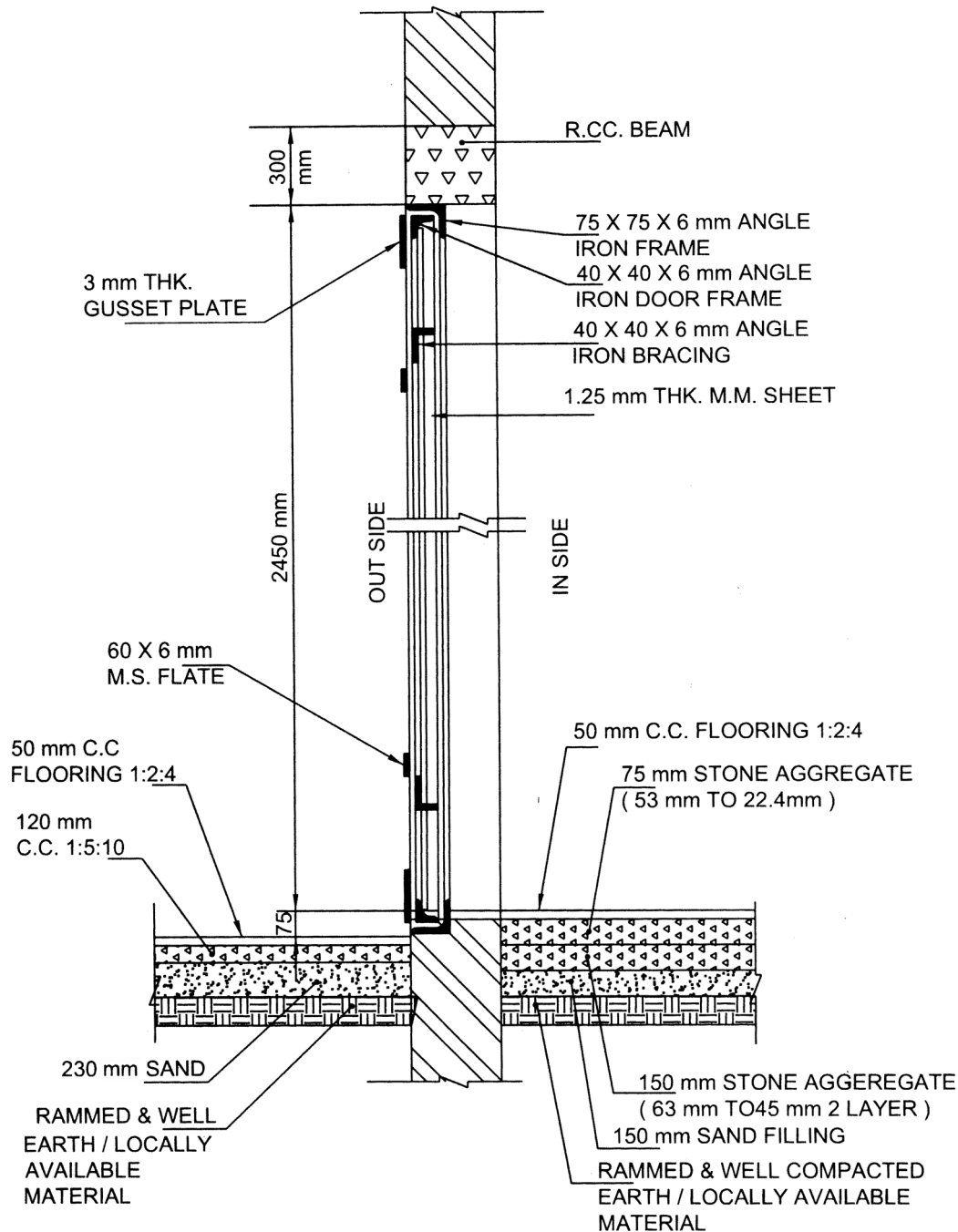

All dimensions in millimetres.

FIG. 8 DETAILS OF STEEL DOOR

steel sheets or corrugated aluminium sheets or black corrugated sheet, not thinner than 0.56 mm. The sheets shall project at least 46 cm from the outer face of the longitudinal walls. The sheets shall be well anchored and secured on the purlins by means of galvanized iron J or L hooks, sufficiently long to have good grip over

sheets and purlins and accommodate nuts and washers. In areas liable to excessive heat, use of a heat reflecting paint may be considered.

12.6 Purlins may be of structural steel rolled or tubular sections. The spacing of purlins shall be as given in IS 3007 (Part 1).

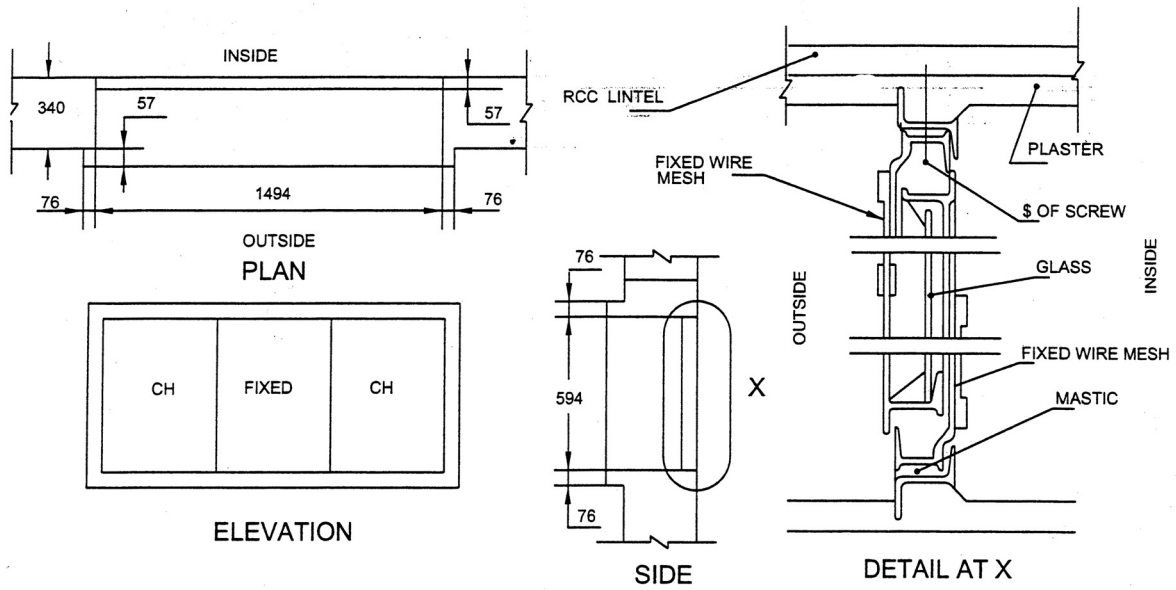

VENTILATOR V AT 15 cm BELOW TOP EDGE OF LONGITUDINAL WALL

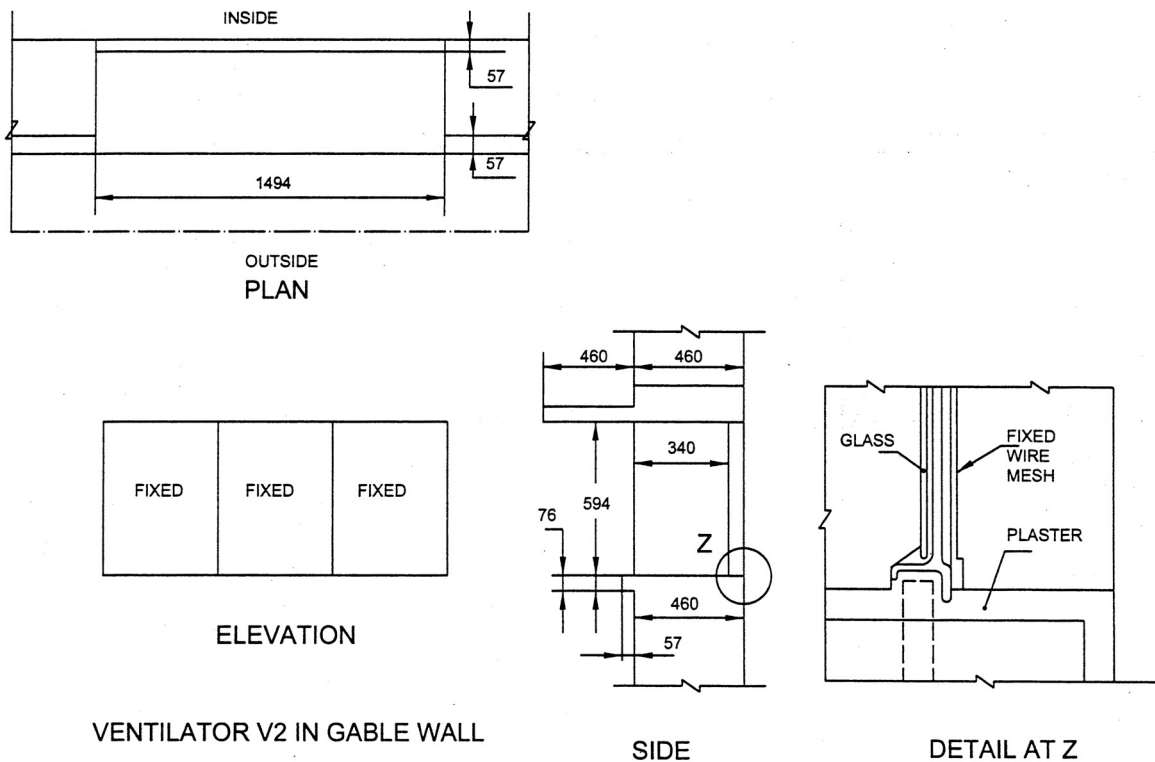

VENTILATOR V2 IN GABLE WALL

All dimensions in millimetres.

FIG. 9 VENTILATORS

IS 16144 : 2014

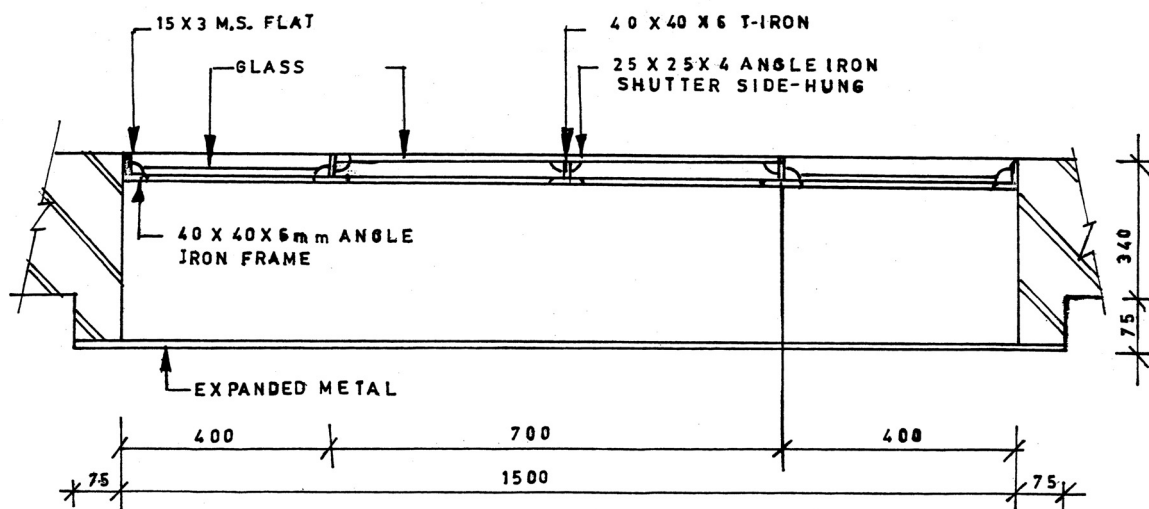

PLAN VENTILANTOR

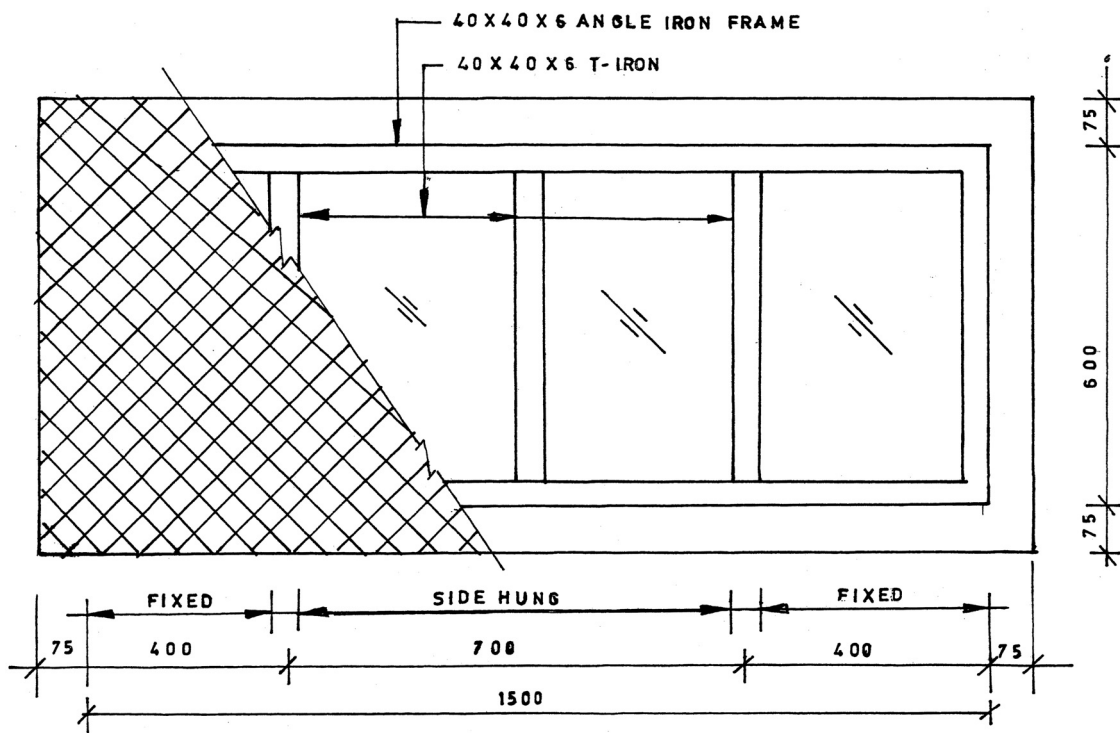

All dimensions in millimetres.

FIG. 10 DETAILS OF TOP VENTILATOR

12.6.1 The design of the purlins shall be in accordance with the general constructional and Indian Standard design practices.

12.6.2 Suitable arrangement shall be provided for expansion of purlins and bottom runners. They may be provided preferably at the partition and gable walls.

12.7 The trusses need not be provided on the gable and partition walls. The purlins may, however, rest and be deeply anchored on the gable and the partition walls.

12.8 Wind ties of MS flat of size 40 mm × 6 mm may be provided in a minimum of 4 rows in the godown and one row on the platform roofing in normal wind

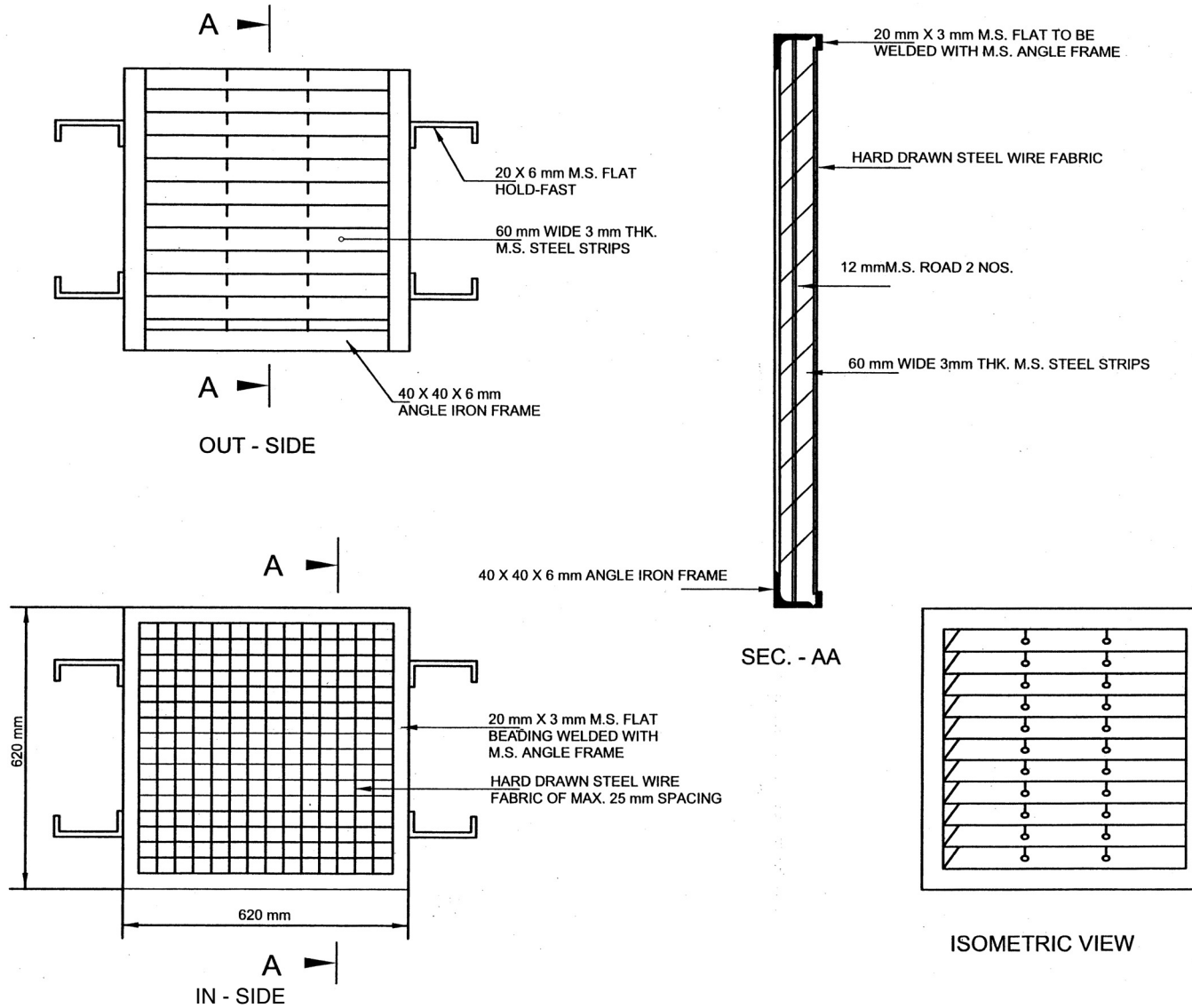

All dimensions in millimetres.

FIG. 11 DETAILS OF BOTTOM LEVEL AIR INLET

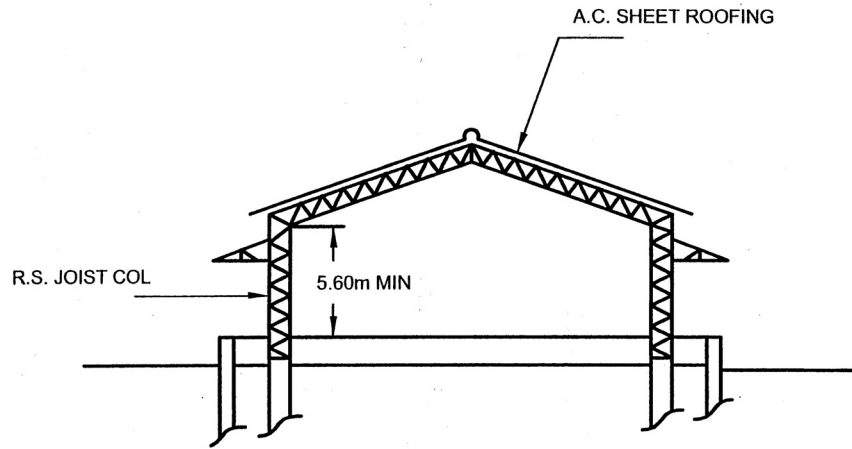

STEEL FRAME TRUSSES
(SPAN 21.8m C/C) GABLE ROOF

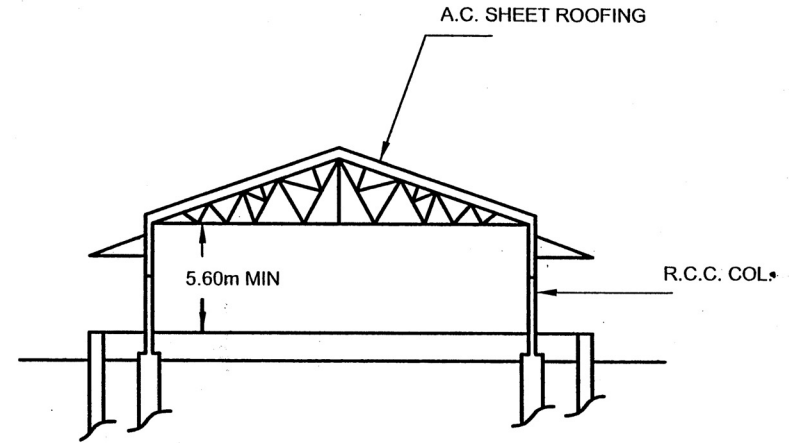

CONVENTIONAL STRUCTURAL STEEL
OR TUBULAR TRUSSES (SPAN 21.8m C/C)

FIG. 12 DIFFERENT TYPES OF ROOFS FOR GODOWNS

zones and on every overlap of sheets in cyclonic or high wind zone areas.

12.9 Transparent/translucent sheets of about 2 percent of the total area of the roof and evenly distributed may be provided for natural light.

12.10 Polyester coated pre-painted sheets may also be considered in the roofing.

13 GABLE AND PARTITION WALLS

13.1 A beam may be provided at the tie level of truss over gable and partition walls. Where gabled roof is constructed, care should be taken that no hollow space is left between the walls and the roof covering.

14 DRAINAGE

14.1 Rain Water Pipes

On rail-side platform, rain water pipes shall be provided at each bay for drainage of rain water from the roof. The rain water eaves gutter at the outer end of the platform truss of adequate section to receive the rain water both from the main godown roof and platform roof shall be provided and suitably connected to the down-take rain water pipes (*see* Fig. 13). They shall be of cast iron, asbestos cement pipes [*see* IS 1626 (Parts 1 and 2)], PVC/HDPE or SWR pipes of diameter not less than 110 mm. Their diameter shall also be adequate depending on the intensity of the rainfall of the place. The pipes shall be properly secured at the off-take and also securely fixed with clamps to the RCC columns or walls at every 1.8 m. The rain water shall be drained off by suitable open drains fairly away from the main godown. Where rail-side platforms are provided, the drain pipes shall be connected to the suitable manholes provided under platform and rain water shall be drained off by asbestos cement pipes, PVC or SWR pipes of adequate diameter connecting the manholes. The manholes shall be provided with heavy-duty covers. On the road-side platforms, a strip of 90 cm brick paving may be provided along the platform walls to protect the scouring of the road

surface from the rain water falling from the roof directly. A suitable saucer drain of 300 mm diameter or V shaped drain may also be provided by the side of platform wall to drain away the rain water of the roof. Surface area drain to carry run off may also be provided for disposal of water of the complex.

15 FINISHING

15.1 The internal faces of the walls of the godowns shall be cement plastered and external faces up to floor level shall be smooth plastered. The internal faces may be whitewashed and external faces provided with colour wash.

15.1.1 All the steelwork and woodwork shall be provided with two coats of superior quality paint over a coat of primer.

15.1.2 The galvanized iron (GI) or aluminum sheets shall be painted with two coats of superior quality paint suitable for GI or aluminum sheets over a coat of primer suitable for such surfaces. Black corrugated sheets where used shall also be painted with suitable paints which prevent rusting and deterioration of these sheets in addition to the priming and finishing coats.

15.1.3 The paint to be used inside the godown for steelwork and steel/aluminium sheets shall resist the adverse effects of fumigants.

15.1.4 In the coastal area, choice of the paint on the steel items/structure should be according to the environmental conditions so as to combat the effect of rusting etc.

15.1.5 In the heavy rainfall areas, external surface of walls should be finished with cement water proofing paint.

16 LIGHTING

16.1 Sufficient lighting may be provided inside in the alleyways and on the outside of the godown to facilitate loading and unloading operations.

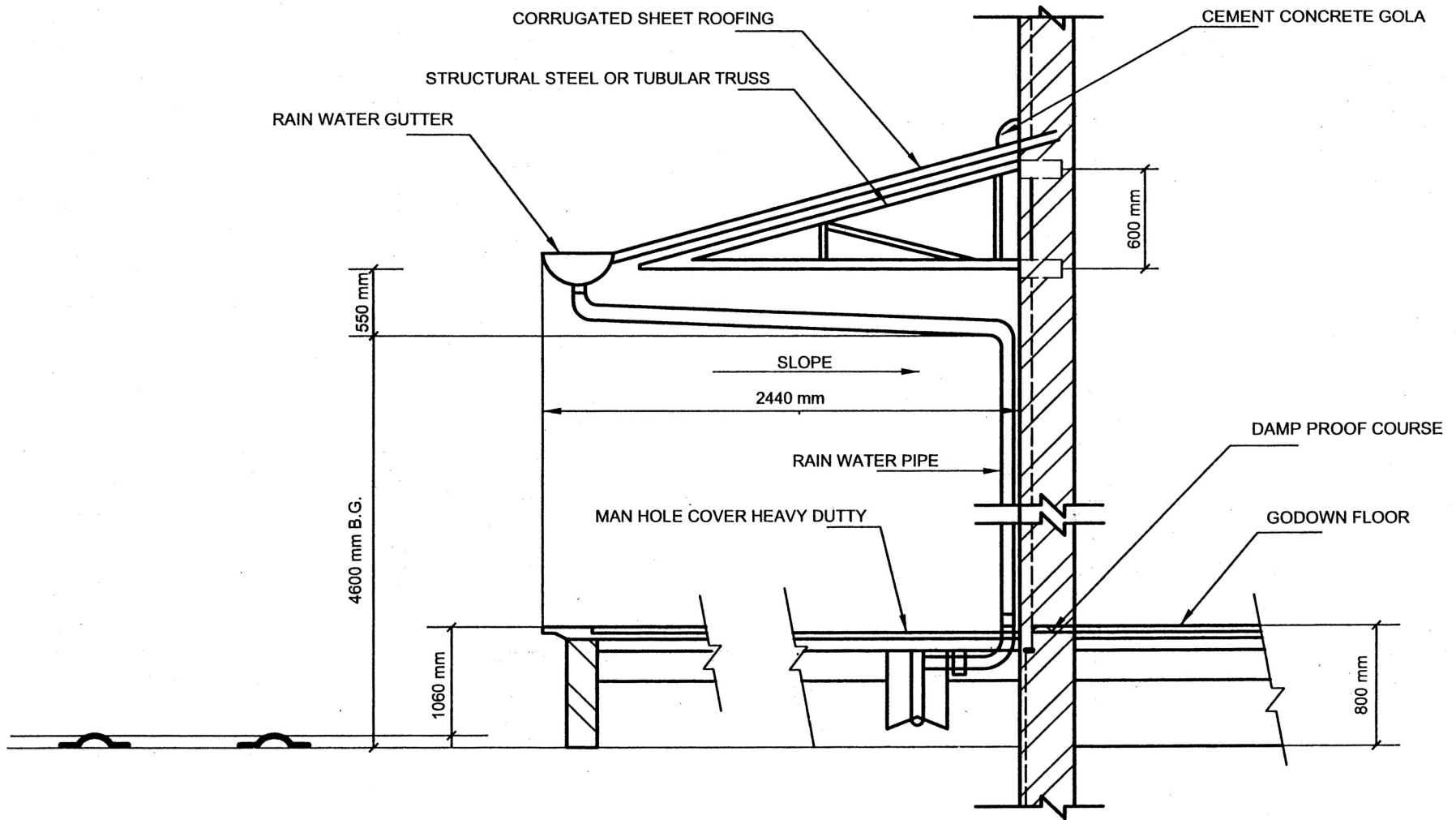

FIG. 13 DETAILS OF EAVES GUTTER AND RAIL-SIDE PLATFORM

ANNEX A
(Clause 5.1)

ANCILLARY STRUCTURES AND OTHER AMENITIES

A-1 There may be one or more ancillary structures at each site depending upon the storage capacity and scope for future expansion. A small compact block consisting of an office room, a store room and a separate room for keeping pesticides shall be provided at each site with proper aeration. For small capacity godowns, the following sized of rooms are suggested which may be modified as per the actual requirements:

a) Office room	4.5 m × 3.5 m
b) Store room	3.5 m × 3.5 m
c) Chowkidar/Sentry room	4.0 m × 2.25 m
d) Cycle/scooter stand	
1) Upto 10 000 MT capacity	14 m ²
2) Above 10 000 and upto 50 000 MT	36 m ²

A-1.1 The area of the office block would depend upon the staff pattern while that for store room would be on the basis of the storage capacity, the anticipated turnover of work, the quantity of dead stock articles, equipment and chemicals that may have to be kept at each centre. A room preferably separate with a suitable *verandah* may be provided for watch and ward purpose. For larger capacity of 5 000 tonnes and more, the following minimum areas are recommended for office block:

	<i>Plinth Area</i>
a) Upto 10 000 MT	100 m ²
b) Above 10 000 and up to 25 000 MT	250 m ²
c) Above 25 000 MT	500 m ²

A-2 For large-capacity storage godowns, the following ancillary structures may be provided for each centre in addition to the administrative block.

A-2.1 Lavatory Block and Sanitary Installation

For labourers and staff working in the premises of the storage godown, sufficient number of bathrooms, urinals, lavatories and washing places shall be provided. The following yard-stick for provision of lavatory block may be suggested:

<i>Storage Capacity</i>	<i>WC</i>	<i>Washing</i>	<i>Drinking Places</i>	<i>Places</i>
a) Up to 5 000 tonnes	1	2	1	1
b) Above 5 000 and up to 10 000 tonnes	2	3	2	2
c) Above 10 000 and up to 25 000 tonnes	3	6	4	4
d) Above 25 000 tonnes	The number may be suitably increased			

A-2.2 Water supply and the fire fighting arrangement shall be made in accordance with the bye-laws of the local fire department.

A-2.3 For the staff and labourers working in the storage godown, facilities for drinking shall be provided at suitable locations.

A-2.4 For firefighting purposes, a network of water supply pipe lines with fire hydrants at suitable locations may be provided to ensure supply of water at any time (*see* IS 3594 and IS 2190).

A-2.5 Canteen

It is recommended that the amenity of a canteen/tiffin room may be provided at each centre having a capacity of 5 000 tonnes or more. The size of canteen may be proportionately increased for godowns of higher capacities.

IS 16144 : 2014

A-2.6 Water Harvesting

It is recommended that the rain water harvesting arrangements may be made in the complex to recharge the ground water level as per the practice in the local PHE and self-government department of the State or Central Ground Water Board.

Bureau of Indian Standards

BIS is a statutory institution established under the *Bureau of Indian Standards Act, 1986* to promote harmonious development of the activities of standardization, marking and quality certification of goods and attending to connected matters in the country.

Copyright

BIS has the copyright of all its publications. No part of these publications may be reproduced in any form without the prior permission in writing of BIS. This does not preclude the free use, in the course of implementing the standard, of necessary details, such as symbols and sizes, type or grade designations. Enquiries relating to copyright be addressed to the Director (Publications), BIS.

Review of Indian Standards

Amendments are issued to standards as the need arises on the basis of comments. Standards are also reviewed periodically; a standard along with amendments is reaffirmed when such review indicates that no changes are needed; if the review indicates that changes are needed, it is taken up for revision. Users of Indian Standards should ascertain that they are in possession of the latest amendments or edition by referring to the latest issue of 'BIS Catalogue' and 'Standards : Monthly Additions'.

This Indian Standard has been developed from Doc No.: FAD 16 (2002).

Amendments Issued Since Publication

Amend No.	Date of Issue	Text Affected

BUREAU OF INDIAN STANDARDS

Headquarters:

Manak Bhavan, 9 Bahadur Shah Zafar Marg, New Delhi 110002
Telephones : 2323 0131, 2323 3375, 2323 9402 Website: www.bis.org.in

Regional Offices:

	Telephones
Central : Manak Bhavan, 9 Bahadur Shah Zafar Marg NEW DELHI 110002	{ 2323 7617 2323 3841
Eastern : 1/14 C.I.T. Scheme VII M, V. I. P. Road, Kankurgachi KOLKATA 700054	{ 2337 8499, 2337 8561 2337 8626, 2337 9120
Northern : SCO 335-336, Sector 34-A, CHANDIGARH 160022	{ 260 3843 260 9285
Southern : C.I.T. Campus, IV Cross Road, CHENNAI 600113	{ 2254 1216, 2254 1442 2254 2519, 2254 2315
Western : Manakalaya, E9 MIDC, Marol, Andheri (East) MUMBAI 400093	{ 2832 9295, 2832 7858 2832 7891, 2832 7892

Branches: AHMEDABAD. BANGALORE. BHOPAL. BHUBANESHWAR. COIMBATORE. DEHRADUN. FARIDABAD. GHAZIABAD. GUWAHATI. HYDERABAD. JAIPUR. KANPUR. KOCHI. LUCKNOW. NAGPUR. PARWANOO. PATNA. PUNE. RAJKOT. VISAKHAPATNAM.